



Specification

Rated Power:3W Peak Power:5W
 Impedance:4Ω ±15%
 Resonant Frequency / fs:550Hz±20%
 Voice Coil diameter: 19mm
 OD:33.0±0.3mm Thickness: 12.5±0.5mm
 Operation temperature: -20 to +60°C
 Operation: 2.45V Sweep Time at 2s
 Power Test:IEC268-5/3.46V/48hrs
 Weight:30g±10%
 Subject to technical modification

Application

The exciter will be glued onto a flat vibrating surface (e.g sound panel, table plate, plasterboard, ceiling panel or glass panel) so that the surface serves as a kind of speaker cone. In contrast to conventional speakers, exciter primarily excites bending waves on the surface to provide a wider radiation. Sound quality and volume depend on the material properties and the dimensions of the mounting surface.

Drawing

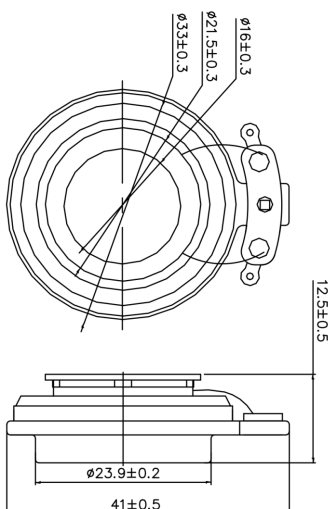

Impedance and frequency curve

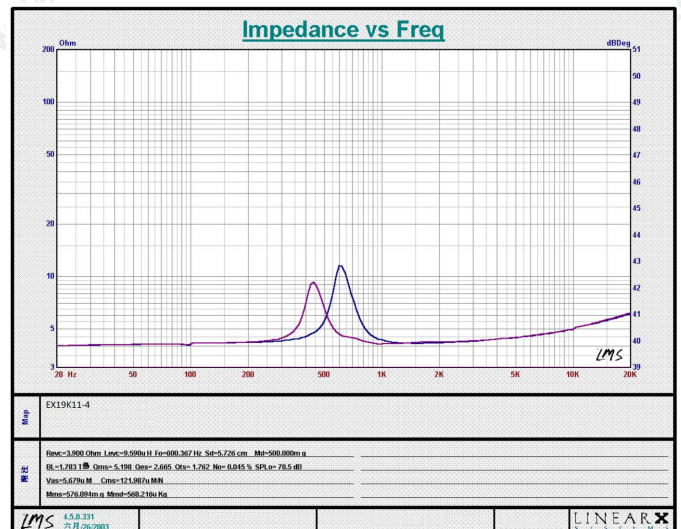

Installation

- 1) Before installing the exciter, make a test run to determine the exciter position for the best sound performance.
- 2) To install exciter, remove the protective film and then glue the exciter onto a clean, flat surface.
- 3) Switch off the amplifier prior to connecting the exciter.
- 4) Connect exciter to a speaker out-put of the amplifier. When connecting exciters to a single output, make sure that they have the same polarity. Do not push the exciter below the minimum load impedance or overloaded

Note: Once the exciter has been mounted to a surface, use a knife to detach the exciter. Never pull the housing, or the exciter may be damaged. The exciter can be reused by changing the adhesive ring.