

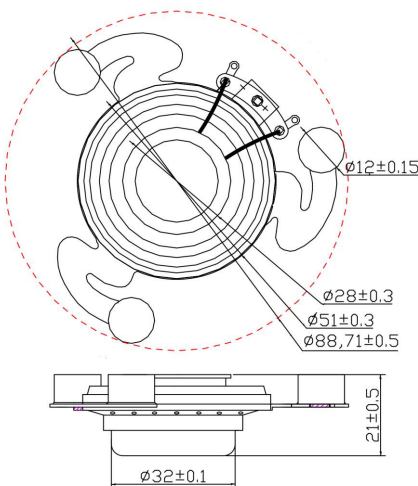

Application

The exciter will be glued onto a flat vibrating surface (e.g sound panel, table plate, plasterboard, ceiling panel or glass panel) so that the surface serves as a kind of speaker cone. In contrast to conventional speakers, exciter primarily excites bending waves on the surface to provide a wider radiation. Sound quality and volume depend on the material properties and the dimensions of the mounting surface.

Drawing



Specification

Rated Power:10W Peak Power:20W
Impedance: $4 \Omega \pm 15\%$
Resonant Frequency / f_s :220Hz $\pm 20\%$
Voice Coil diameter: 25mm
OD: 88.71 ± 0.5 mm Thickness: 21 ± 0.5 mm
Operation temperature: -20 to +60°C
Operation: 4.47V Sweep Time at 2s
Power Test:IEC268-5/7V/48hrs
Weight: $80g \pm 10\%$

Subject to technical modification

Impedance and frequency curve

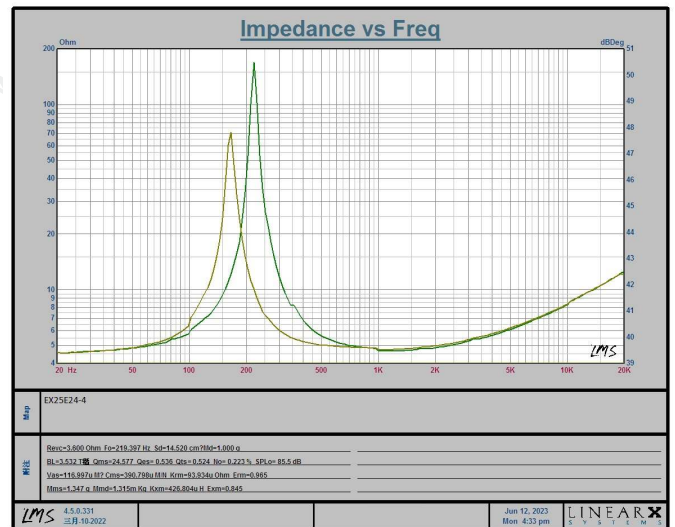

Installation

- 1) Before installing the exciter, make a test run to determine the exciter position for the best sound performance.
- 2) To install exciter, remove the protective film and then glue the exciter onto a clean, flat surface.
- 3) Switch off the amplifier prior to connecting the exciter.
- 4) Connect exciter to a speaker out-pu of the amplifier. When connecting exciters to a single output, make sure that they have the same polarity. Do not push the exciter below the minimum load impedance or overloaded

Note: Once the exciter has been mounted to a surface, use a knife to detach the exciter. Never pull the housing, or the exciter may be damaged. The exciter can be reused by changing the adhesive ring.